

STAINLESS STEEL 316L PRESS FIT FITTINGS (M PROFILE)

COMPLY WITH BSEN1254-2: 1998

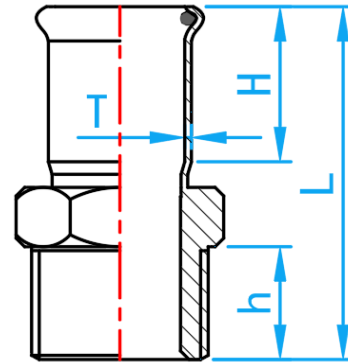

MI SOCKET



CROSS SECTIONAL VIEW

DIMENSIONS

SKU	SIZE (mm x inch)	L (mm)	H (mm)	h (mm)	T (mm)	WEIGHT (kg)	PCS/CTN
SS316LMIA01515	15×1/2"BSPT	51.0	20	15	1.5	0.044	420
SS316LMIA02015	22×1/2" BSPT	53.0	20	15	1.5	0.060	170
SS316LMIA02020	22×3/4" BSPT	55.0	21	16	1.5	0.065	200
SS316LMIA02025	22×1" BSPT	70.0	24	16	1.5	0.105	130
SS316LMIA02515	28×1/2" BSPT	66.5	24	14	1.5	0.075	130
SS316LMIA02520	28×3/4" BSPT	58.0	24	16	1.5	0.082	130
SS316LMIA02525	28×1" BSPT	62.0	33	19	1.5	0.105	130
SS316LMIA03515	35×1/2"BSPT	76.0	26	15	1.5	0.095	80
SS316LMIA03520	35×3/4"BSPT	75.0	26	15	1.5	0.100	80
SS316LMIA03525	35×1"BSPT	67.0	26	21	1.5	0.120	80
SS316LMIA03535	35×11/4"BSPT	70.0	26	21	1.5	0.160	80
SS316LMIA03542	35×11/2"BSPT	82.0	28	22	1.5	0.165	66
SS316LMIA03550	35×2"BSPT	92.0	26	26	1.5	0.300	38
SS316LMIA04215	42×1/2"BSPT	81.0	31	14	1.5	0.120	50
SS316LMIA04220	42×3/4"BSPT	82.0	31	16	1.5	0.132	50
SS316LMIA04225	42×1"BSPT	84.0	24	22	1.5	0.150	50
SS316LMIA04235	42×11/4"BSPT	75.0	31	21	1.5	0.180	50
SS316LMIA04242	42×11/2"BSPT	75.0	31	21	1.5	0.195	66
SS316LMIA04250	42×2"BSPT	96.0	31	21	1.5	0.320	50
SS316LMIA05020	54×3/4" BSPT	94.0	35	16	1.5	0.178	60
SS316LMIA05025	54×1" BSPT	95.0	35	19	1.5	0.198	50
SS316LMIA05035	54×11/4" BSPT	96.0	35	20	1.5	0.232	38
SS316LMIA05042	54×11/2" BSPT	95.0	35	21	1.5	0.246	38
SS316LMIA05050	54×2" BSPT	88.0	36	26	1.5	0.320	38
SS316LMIA06565	67×21/2"BSPT	110.0	50	30	1.8	0.735	15
SS316LMIA08065	76×21/2"BSPT	115.0	55	30	2.0	0.626	24
SS316LMIA08080	76×3" BSPT	117.0	55	32	2.0	0.825	24
SS316LMIA100100	108×4" BSPT	148.0	80	35	2.0	1.243	10