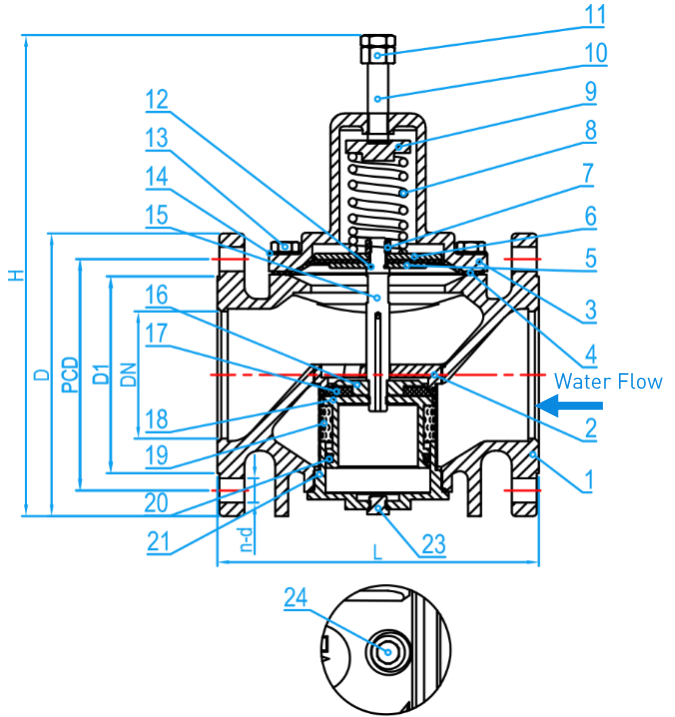
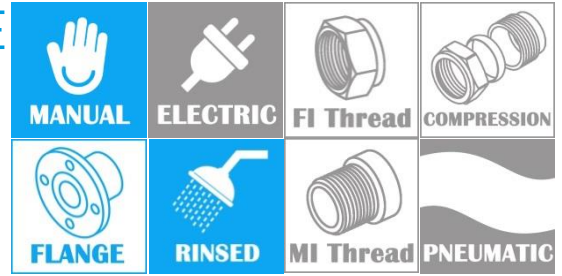
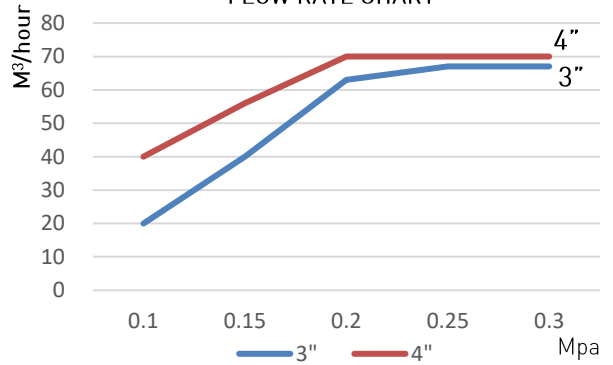

PRESSURE REDUCING VALVE (DIRECT OPERATED) PISTON TYPE

COMPLY WITH BS EN 1567-2000
BS EN 1092-2:1997

COMPONENT PARTS

ITEM	PARTS	MATERIAL
1	Body	Bronze
2	Support	Bronze
3	Upper Bonnet	Bronze
4	Diaphragm	EPDM
5	Lower Diaphragm Pressure Ring	AISI304
6	Upper Diaphragm Pressure Ring	AISI304
7	Nut	EPDM
8	Spring	AISI304
9	Spring Seat	Brass
10	Hexagon Bolt	AISI304
11	Hex Nut	AISI304
12	O-ring	EPDM
13	Hexagon Bolt	AISI304
14	Washer	AISI304
15	Valve Stem	AISI304
16	Valve Disc Pressure Plate	Bronze
17	Valve Disc	EPDM
18	Valve Disc Holder	Bronze
19	Filter Screen	AISI304
20	Bowl Shaped Ring	EPDM
21	Lower Bonnet	Bronze
22	O-ring	EPDM
23	Screw Plug	AISI304
24	Screw Plug	AISI304

FLOW RATE CHART

STANDARD SPECIFICATIONS

Nominal Pressure	0.1 to 1.6MPa
Working Medium	Water
Working Temperature	0°C ≤ t ≤ 80 °C
Max Inlet Pressure	1.6Mpa
Outlet Pressure Adjustable Range	0.1~0.3Mpa
Initial Set Outlet Pressure	0.2Mpa

DIMENSIONS

SKU	Size (mm)	DN (mm)	L (mm)	D1 (mm)	n-d	PCD (mm)	D (mm)	H (mm)	WEIGHT (kg)	PCS/CTN
PRVCRN080F	80	80	225	138	8-18	160	200	370	19.500	1
PRVCRN100F	100	99	250	157	8-18	180	220	400	28.995	1