

DZR BRASS PISTON SPRING CHECK VALVE F x F

COMPLY WITH BS 5154:1991
 AS/NZS 4020:2018
 BS EN 12165:2016
 BS EN 12288:2010
 SS 375:2015
 SS 270:2015

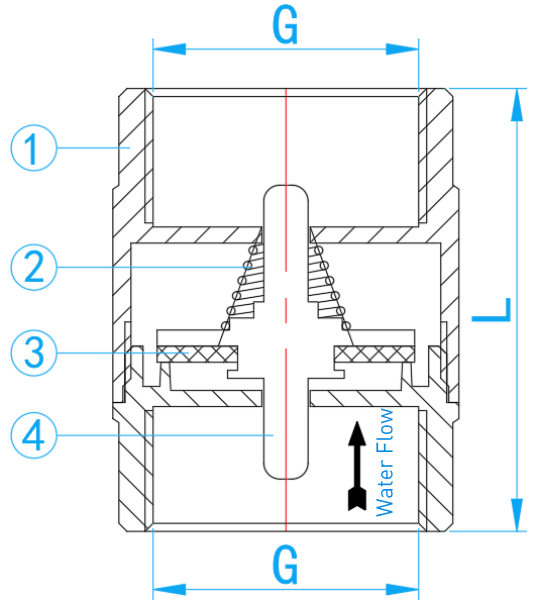

CROSS SECTIONAL VIEW

STANDARD SPECIFICATIONS

Working Pressure	200 Psi
Applicable Medium	Water

COMPONENT PARTS

ITEM	PARTS	MATERIAL
1.	Body	DZR Brass
2.	Spring	AISI304
3.	Gasket	EPDM
4.	Spool	DZR Brass

DIMENSIONS

SKU	SIZE (mm)	G (inch)	L (mm)	WEIGHT (kg)	PCS/CTN
CVCRNB015	15	1/2" BSP	42.5	0.115	200
CVCRNB020	20	3/4" BSP	51.0	0.170	100
CVCRNB025	25	1" BSP	55.0	0.222	90
CVCRNB035	35	1 1/4" BSP	64.5	0.390	48
CVCRNB042	42	1 1/2" BSP	73.5	0.575	40
CVCRNB050	50	2" BSP	81.5	0.880	24
CVCRNB065	65	2 1/2" BSP	88.0	1.365	16