

213 uPVC ANTI-MOSQUITO/ INSECT TRAP DEVICE WITH FILTER

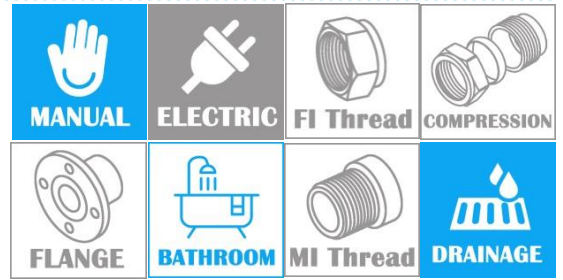

norika
norika

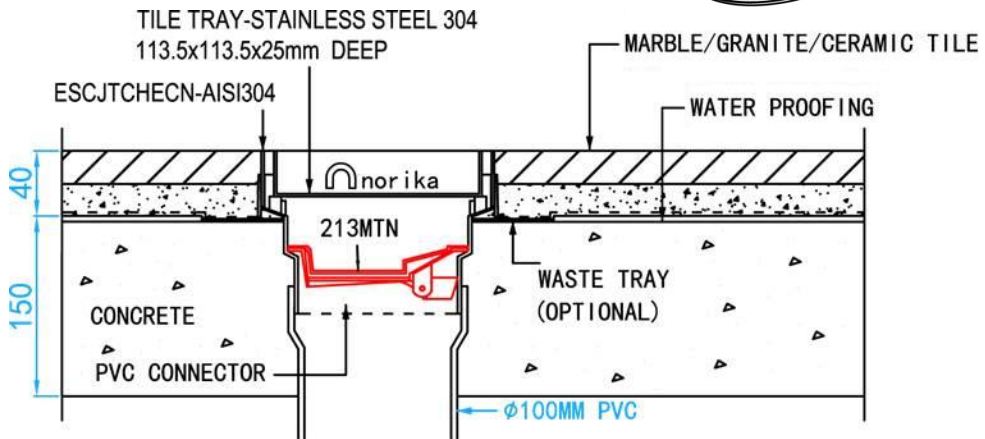
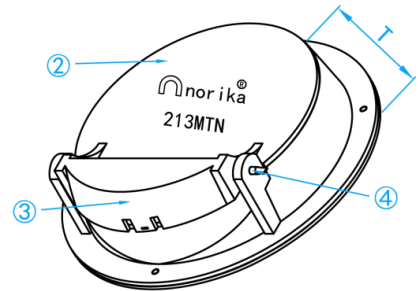
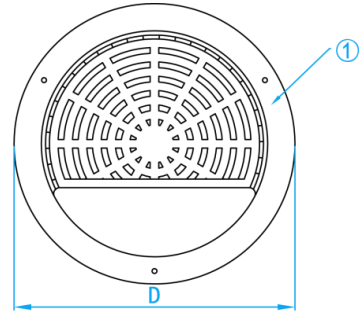

APPLICATIONS

For prevention of insect pest from crawling out from the drainage. To be fitted on the opening of gratings.

DIMENSIONS

SKU	D (mm)	T (mm)	WEIGHT (kg)	PCS/CTN
213MTN (White Colour)	96.5	24	0.069	100
213MTNB (Black Colour)	96.5	24	0.069	100

COMPONENT PARTS

ITEM	PARTS	MATERIAL
1	Filter	ABS
2	Trap	ABS
3	Weight	Lead
4	Retaining Pin	Nylon