

# PRECHARGE PRESSURE TANK

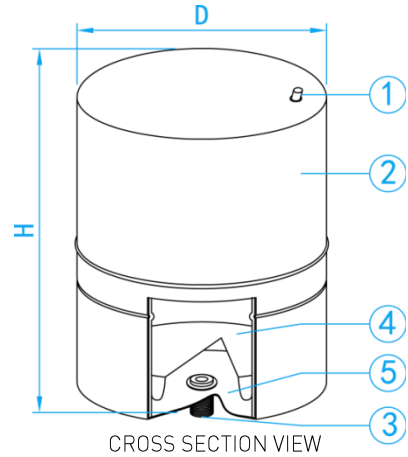

COMPONENT PARTS	
ITEM	PARTS
1	Sealed Air Valve
2	Double Layer Painting
3	Stainless Steel Connection
4	Food-Grade Butyl Membrane
5	Food-Grade PPliner

STANDARD SPECIFICATIONS	
Working Pressure	10 Bar
Working Temperature	-10°C ≤ t ≤ 100 °C
Pre-set Pressure	2 Bar

## CHARACTERISTIC

- Special sealing in air-valve cover against air-leakage.
- In fix membrane potable water tanks, water is between stainless steel connection tube, food-grade polypropylene liner and food-grade butly diaphragm. By help of this tank design, water quality will not be poluted by the internal part of tank metal body and also external environments.
- The tanks have stainless steel connection to provide hygienic standarts for potable water.

## INSTALLATION

- In the heating system, it is recommended that the pressure tank be installed at the lowest point of the water temperature of the system and installed on the backwater end of the system near the cold water inlet of the heat storage water tank. Please ensure the appropriate use of the process.
- safety valves shall be installed near the pressure tank to avoid damage to the pressure tank and other parts of the system incase the system pressure is abnormal.
- Tank should not be installed at the outlet of the pump where the heating and air conditioning cycles take place. This may cause the water pump cavitation.
- The user shall not be allowed to charge or deflate the pressure tank, otherwise, if the product fails due to improper usage, our company will not be responsible for it! (Pre-set pressure shall not exceed 4kg.)

## DIMENSIONS

SKU	D (mm)	H (mm)	Volume (Litres)	Male Connector	WEIGHT (Kg)	PCS/CTN
WX102	300	440	24	1" (BSP)	4.80	1