

# PPR PIPE & FITTINGS WELDING MACHINE

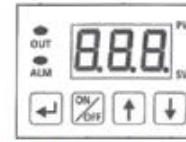

CONTROL PANEL

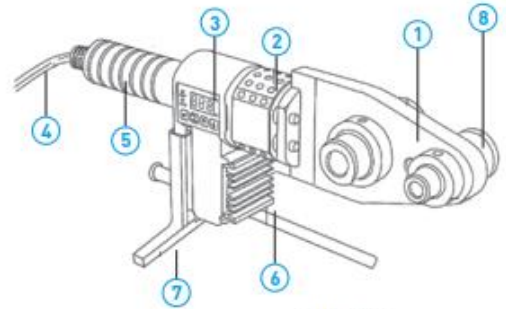

3-D VIEW

### STANDARD SPECIFICATIONS

VOLTAGE RATING	230V~240V
POWER RATING	1200W
CURRENT RATING	3.75A
WORKING RANGE	DN 20 ~ 63mm DN 75~110mm
TEMPERATURE RANGE	0°C ~ 320°C
DIMENSIONS	420 x 175 x 125 mm

### COMPONENT PARTS

ITEM	PARTS
1	Heating Plate
2	Power Circuit Cooling Chamber
3	Control And Regulation Panel
4	Power Supply Cable
5	Hand Shank
6	Electronic Circuit Fin Cooler
7	Seat
8	Adaptors
9	Hexagon Spanner

### WELDING TABLE FOR P.P TUBES

SKU	TUBE DIAMETER (mm)	TUBE HEATING DEPTH (mm)	HEATING TIME (sec)	PROCESSING TIME (sec)	COOLING TIME (min)	WEIGHT (kg)	PCS/CTN
PPRMN63	20	14	5	4	3	3.18	1
	25	16	7	4	3		
	32	20	8	4	4		
	40	21	12	6	4		
	50	22.5	18	6	5		
PPRMN110	63	24	24	6	6	7.8	1
	75	26	30	10	8		
	90	32	40	10	8		
	110	38.5	50	15	10		

\*Above heating time based on 260°C.

\*When temperature reaches setting, please wait for 15mins to allow temperature to stabilize before use.